

Unpacking

Before using the device, check the device model and ensure that the shipped box includes the following items:

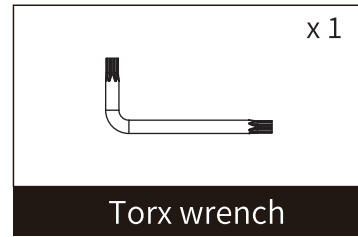
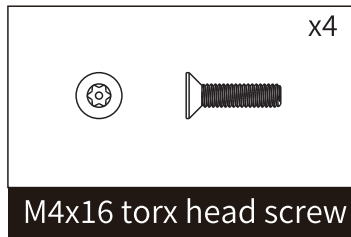
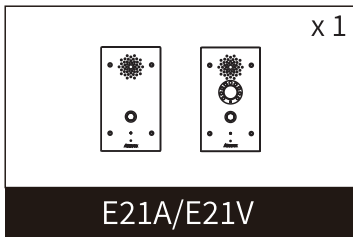

Optional Accessories:

Flush-mounting Accessories (Please find in In-Wall Installation Kit box)

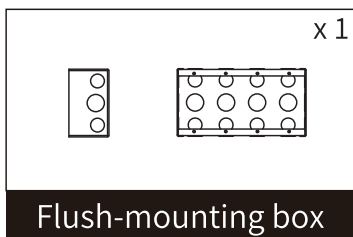

Product Overview

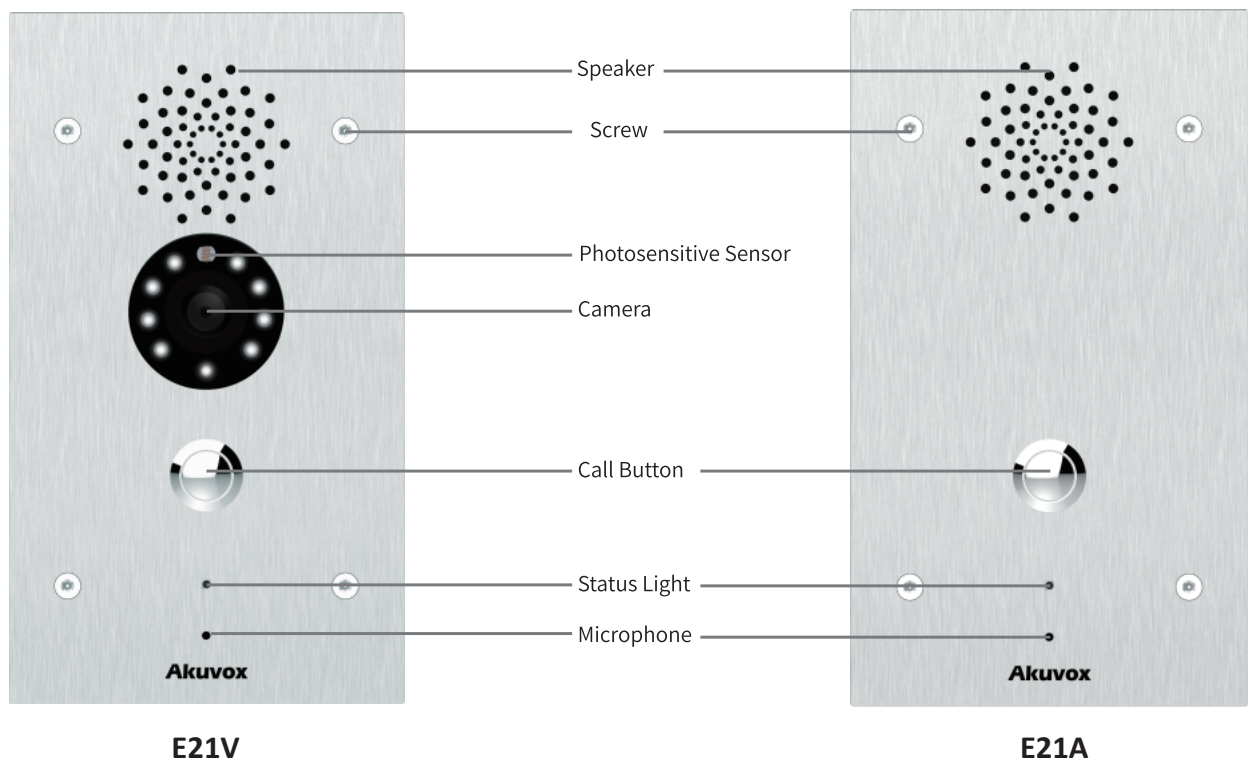

Before You Start

Tools needed

(not included in shipped box)

- Cat Ethernet Cable
- Crosshead Screwdriver

Voltage and Current Specifications

- It is suggested that use PoE or 12VDC 1A power adapter to power on device.

AWG Sizes and Properties Table

Please follow the properly wire data to install device:

Power Supply	12VDC 1A				
AWG	16	18	20	22	24
Resistance (ohm/km)	13.5	21.4	33.9	48.5	79.6
Cross-sectional Area (mm ²)	1.318	0.8107	0.5189	0.3247	0.2047
Wire Length (m)	≤50	≤50	≤50	≤40	≤20

Requirements

1. Place the device away from sunlight and light sources to prevent potential damage.
2. Do not place the device in the high-temperature, and humid environments or in surroundings impacted by magnetic field.
3. Install the device on the flat surface securely to avoid personal injuries and property loss caused by device's falling.
4. Do not use or place the device near heating objects.
5. If installing the device indoors, please keep device at least 2 meters away from light, and at least 3 meters away from window and door.

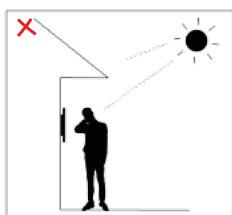

Backlight

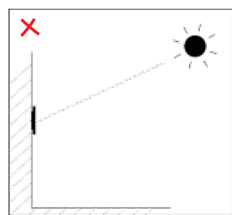

Direct sunlight

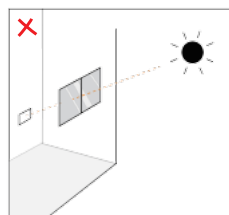

Direct sun through window

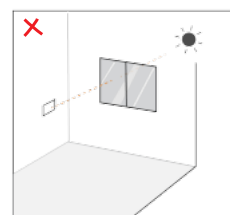

Indirect sunlight through window

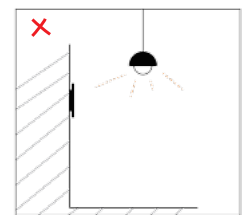

Close to light

Warning!

- 1.To ensure safety, avoid touching power core, power adapter, and device with wet hands, bending or pulling the power core, damaging any components, and use only qualified power adapter and power cord.
- 2.Be careful that standing up on the area under the device in case of personal injuries cause by hitting the device.

Cautious

- 1.Do not knock device with hard objects.
- 2.Do not press down hard on the device screen.
- 3.Do not expose device to chemical products, such as alcohol, acid liquid, disinfectants, and so on.
- 4.To prevent the device installation from becoming loose, ensure accurate diameters and depths of screw holes. If the screw holes are too large, use glue to secure the screws.
- 5.Use wet cloth clean device surface softly, and then wipe the surface with dry cloth for cleaning the device.
- 6.If there is abnormal situation of the device, including uncommon sound and smell, please power off the device and contact Akuvox Technical Team immediately.

Wiring Interface

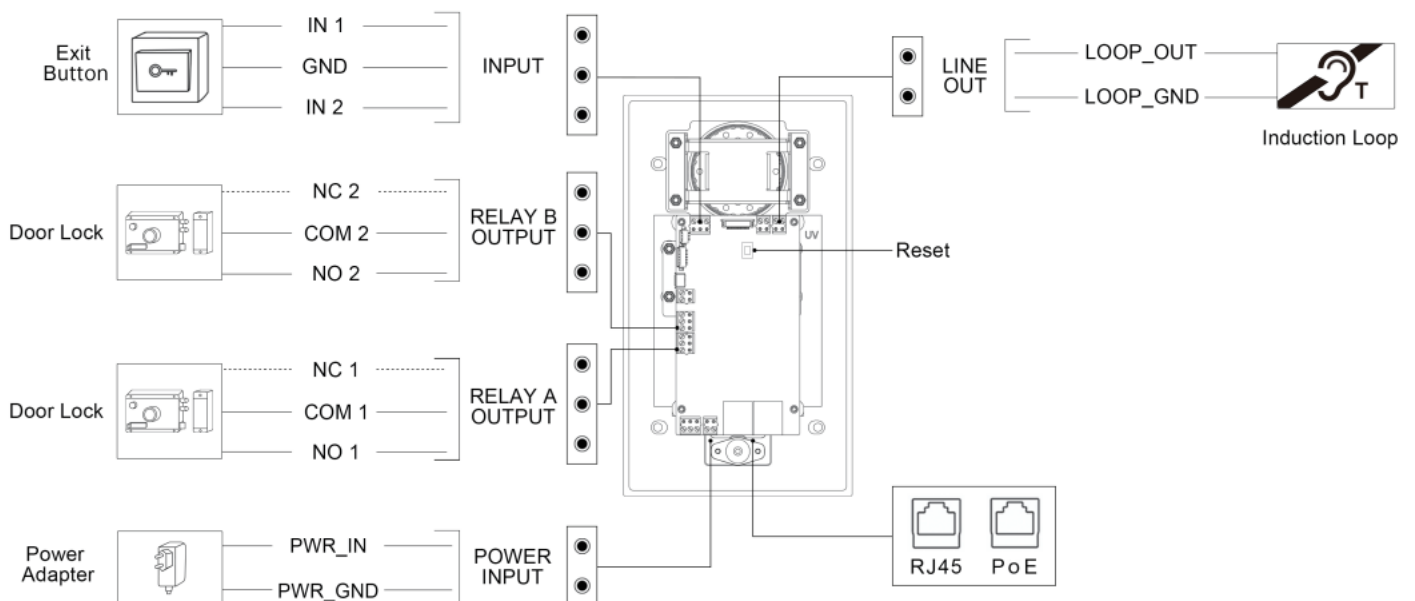

Installation

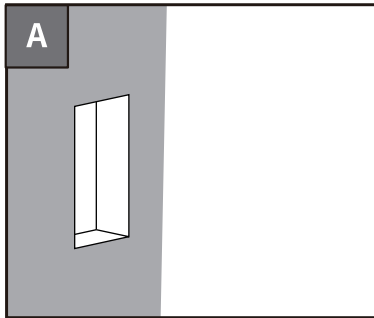

According to the position of the cable, cut out a square hole on the wall with the dimension 190*100*60mm (height*width*depth).

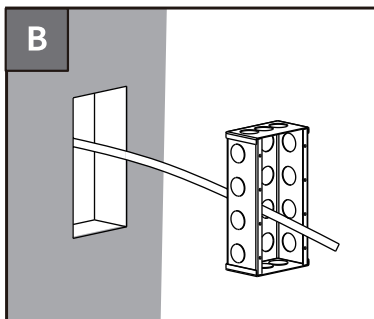

- Knock out suitable cable holes of **flush-mounting box**.
- Lead all cables go through the cable hole.
- Place **flush-mounting box** into the square hole.

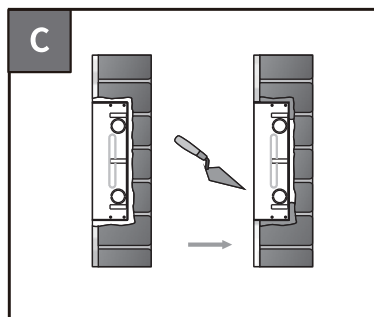

- If there is a gap between **flush-mounting box** and wall, use cement or non-corrosive structural adhesive to fill the gap.
- Ensure that the adhesive material dry before proceeding to the next step.

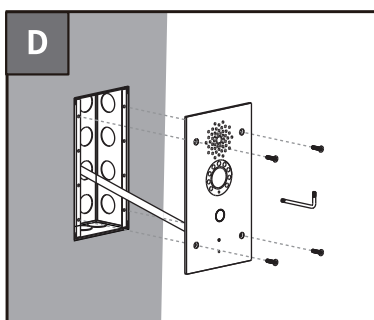

Fix device on the **flush-mounting box** with four **M4X16 torx head screws**.

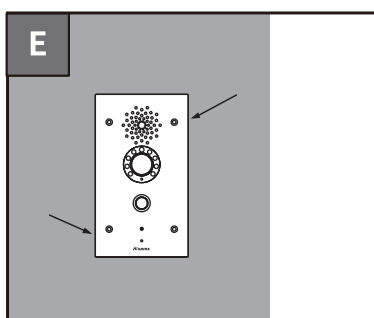

To prevent water from entering the device, apply waterproof adhesive along the junction between the device and the wall.

Application Network Topology

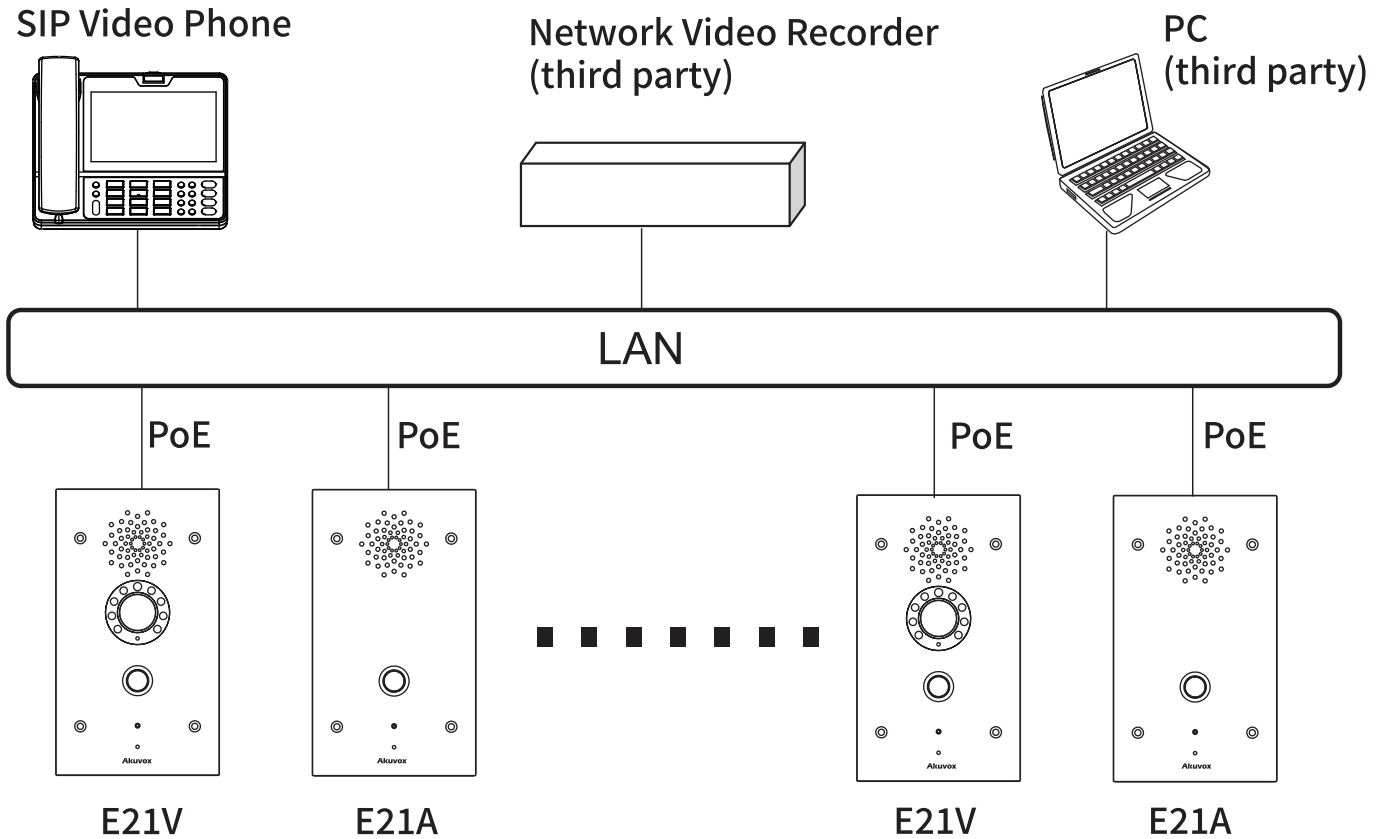

LED Status Information

LED Status		Description
Blue	Always on	Normal status
	Flashing	Calling
Red	Flashing	Offline
Green	Always on	Talking on a call
	Flashing	Receiving a call

Note: For more LED settings, please check in **Intercom > LED Setting** of E21X Web UI.

Device Test

Please verify the device status after installation:

1. **Network:** Press and hold **Call button** to obtain IP address, network is working properly if the device announce IP address. If no IP address is obtained, E21X will announce “IP 0.0.0.0”.
2. **Intercom:** Press **Call button** to make a call. The call configuration is correct if the call is successful.

Warranty

1. Akuvox warranty does not cover intentional mechanical damage or destruction caused by improper installation.
2. Do not attempt to modify, alternate, maintain, or repair device by yourself. Akuvox warranty does not apply to damages caused by anyone who is not representative of Akuvox or an Akuvox authorized service provider. Please contact Akuvox Technical Team if the device need to be repaired.

Get Help

For help or more assistance, contact us at:

 <https://ticket.akuvox.com/>

 support@akuvox.com

Scan the QR code to get more videos, guides, and additional product information.



Notice Information

Information contained in this document is believed to be accurate and reliable at the time of printing.

This document is subject to change without notice, any update to this document can be viewed on Akuvox' s website: <http://www.akuvox.com> © Copyright 2023 Akuvox Ltd. All rights reserved.

