



## SUB 20 A Active Subwoofer

### Description

---

The SUB 20 A is an active, very compact subwoofer with 200 watts of amplifier power and professional features. It produces remarkable bass levels thanks to a high-power 6.5" long excursion driver in a double-vented bandpass cabinet. Thanks to its slim design, compact dimensions and defined sound outlets, it can be easily concealed in furniture and fittings.

The SUB 20 A has four different inputs (mono RCA, stereo RCA, symmetrical XLR and screw-type terminals for speaker level) as well as limiters, automatic switch-on, a continuously adjustable crossover frequency and ground lift switches.

For easy integration into larger installations, the SUB 20 A has the same remote control functions as our amplifiers in the PA series: a contact for remote ON/OFF and a VCA input for synchronous volume control. The connectors are recessed to ensure that the plugs and cables can be hidden from sight.

### Key Features

---

- Active bandpass subwoofer
- Very compact design
- 6.5" long excursion driver
- 200 watts amplifier power
- Cinch, XLR and speaker level inputs
- Auto ON/OFF
- Peak Limiter
- Stand-by contact
- VCA input
- Standard finish: white and black

### Fields of Application

---

- Conference rooms
- Exhibitions, trade fairs
- Gastronomy, hotels
- Home audio
- Shops, sales rooms
- Surround systems

## SUB 20 A Active Subwoofer

### Dimensions

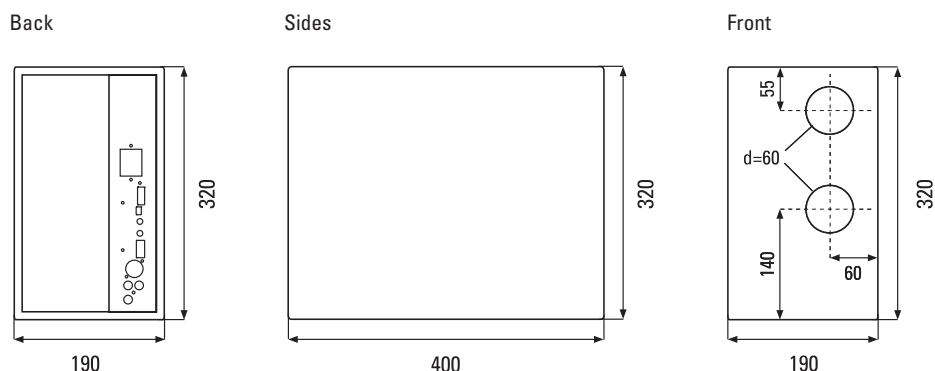

### Technical Data

Principle	Active double vented bandpass subwoofer
Components	6.5" long excursion driver
Amplifier section	Adjustable input sensitivity, switchable gain 0/+6 dB, peak limiter, steplessly adjustable crossover frequency 50 Hz – 150 Hz (36 dB/oct.), switchable phase 0°/180°. Subsonic filter 35 Hz, automatic switch-on circuit, cutoff with 5 min. delay, manual ON/OFF, ground lift switch, remote volume control via external panel (WP-V) or via DV module and UP/DOWN contacts, control voltage 0–15 V, 0 V = max., 10 V = -80 dB, 15 V = mute, stand-by contact (N/O)
Inputs	Mono cinch, stereo cinch, balanced XLR, speaker level input with screw-type terminals
Frequency range	38 Hz – 130 Hz
Amplifier output	200 watts
Maximum SPL	114 dB @ 1 m, half-space
Power supply	230 V AC
Dimensions (W × H × D)	190 × 320 × 400 mm (without rubber feet)
Weight	8 kg
Cabinet	Plywood, semi-matt varnish
Mains	IEC connector
Input sensitivity	Switchable: Cinch 0 dBu/-6 dBu XLR +4 dBu/-2 dBu Speaker level 20 V eff./ 10 V eff.
Warranty	5 years

### Model

### Order-No.

### Version

<b>SUB 20 A White</b>	1310-0003	RAL 9016
<b>SUB 20 A Black</b>	1310-0004	RAL 9005

Other colours and versions on request

# SUB 20 A

## Active Subwoofer

### Amplifier backside with controls

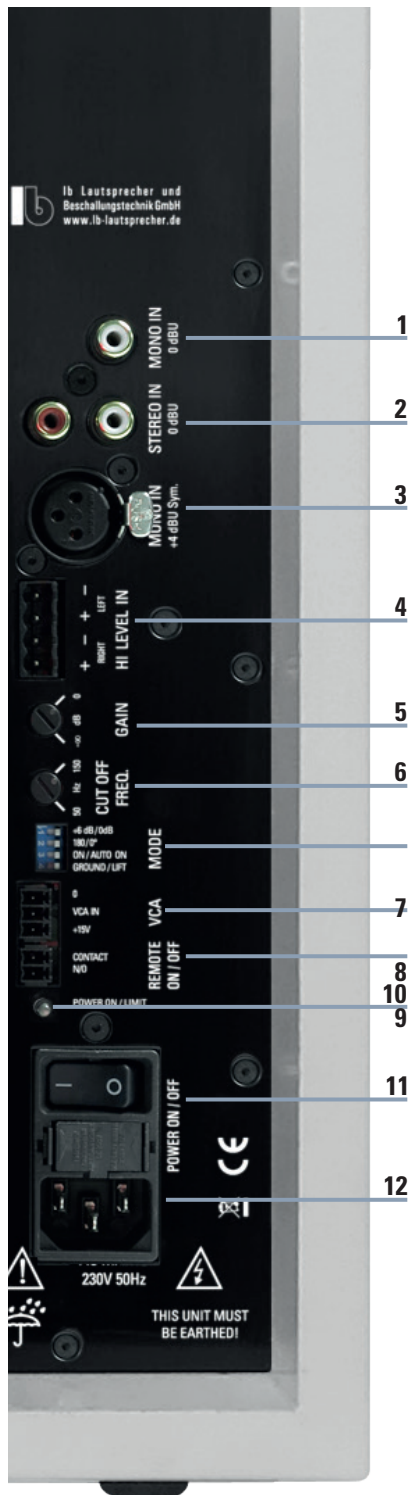

- 1 MONO IN (0 dBu)**  
Mono cinch input for subwoofer signals, for example directly from AV receivers.
- 2 STEREO IN (0 dBu)**  
Stereo cinch input for audio signals. The subwoofer is connected parallel to the amplifier for the satellite speakers and provides internally for sum-to-mono.
- 3 MONO IN IN (symmetrical, +4 dBu)**  
Symmetrical mono input (XLR) for connection to professional sound systems.
- 4 HI LEVEL IN (+28 dBu / 20Vrms)**  
Stereo input for high-level signals. The subwoofer is connected parallel to the amplified signals of the satellite speakers and provides internally for sum-to-mono. This input is also suitable for full-bridge amplifier outputs.
- 5 GAIN**  
Fader control for adjusting the maximum level.
- 6 CUT OFF FREQ.**  
Potentiometer for adjusting the upper crossover frequency. The crossover frequency can be adjusted freely here to between 50 and 150 Hz and should be adapted to the satellite speakers in the system. The filter slope is 36 dB per octave.
- 7 MODE**
  - 7.1 +6 dB / 0 dB**  
Switchable gain for increasing input sensitivity for weak signal sources.
  - 7.2 180° / 0°**  
To adapt the phase in the frequency range to the satellite speakers, the phase can be switched between 0° and 180°.
  - 7.3 ON/AUTO ON**  
With the switch set to ON, the subwoofer is permanently on. With the switch set to AUTO ON, the automatic switch-on function is activated, and the subwoofer is switched off after approx. 5 minutes when not receiving an audio signal.
  - 7.4 GROUND/LIFT**  
With the switch set to GROUND, the audio ground is connected to the protective ground conductor. To prevent ground loops, hard grounding in the LIFT switch setting is not implemented for the audio ground.
- 8 VCA**  
Input for external volume control using our WP-V and RP-V volume controllers, with the DV module (digital volume control module) and up/down contacts or with 0 - 10 V dimmer actuators (0 V = nominal gain, 10 V = -80 dB reduction, 15 V = mute).
- 9 REMOTE ON/OFF**  
Using this contact, the subwoofer can be switched off using an isolated contact.
- 10 LED POWER ON/LIMIT**
- 11 POWER ON/OFF**  
Mains switch.
- 12 Low-voltage mains connection**  
Connect to the mains supply using the power cable provided.

# SUB 20 A Active Subwoofer

## Block Diagram

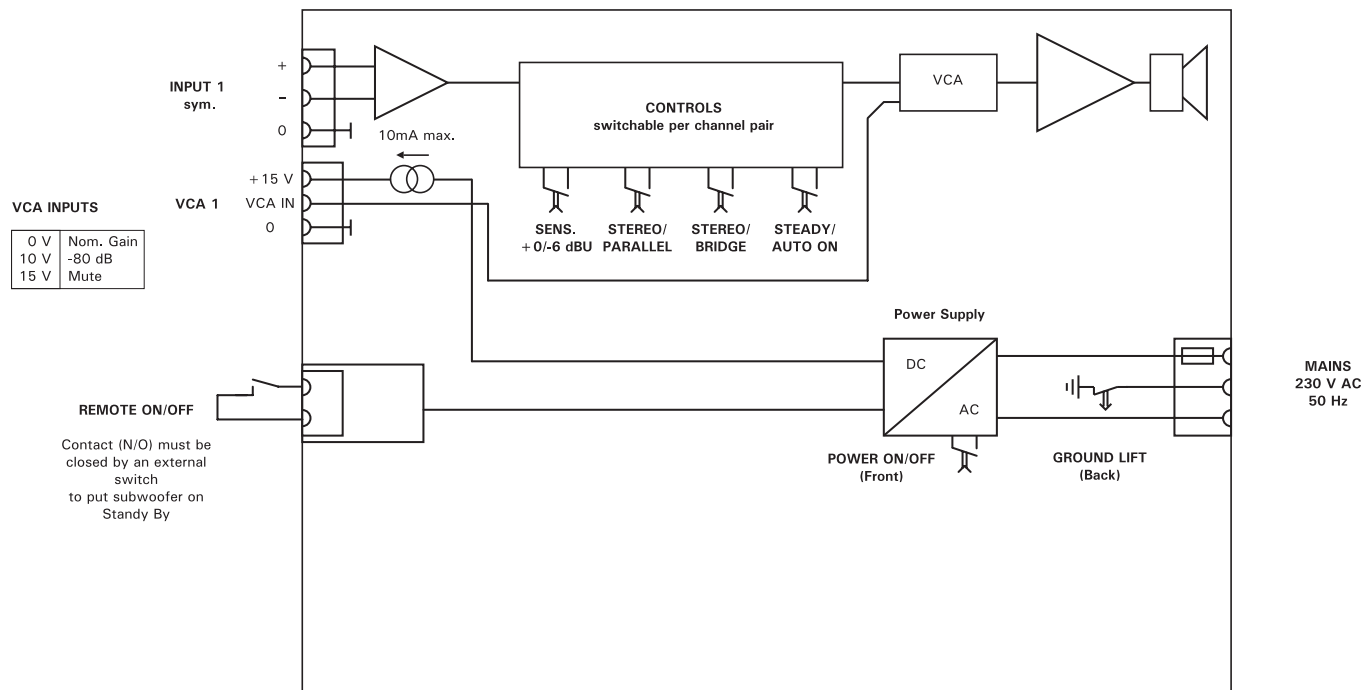

## Measuring Diagram

SUB 20 A frequency response (high-cut 50/80/110/150 Hz)

