

## ZL 50 Line Array Speaker



### Description

The ZL 50 is a short, highly focused speaker line array for targeted acoustic irradiation with a long throw.

The ZL 50 is also often used in exhibitions and presentations – in conjunction with monitors and projection screens – to create a very narrow path of sound. To do this, multiple ZL 50 and ZL 100 devices can be connected to create a sound path with the desired width.

Six highly efficient, extremely linear 2.5" full-range drivers with precise electronic frequency response linearization can be used to achieve excellent reproduction characteristics for clear speech and maximum directivity.

Thanks to its modular design, the ZL 50 can be combined with other models from the ZL series to create longer arrays. We recommend using the SUB 20 or SUB 40 subwoofers to supplement the low frequency range.

### Key Features

- Sharply focused line array
- $120^{\circ} \times 20^{\circ}$  dispersion
- $6 \times 2.5''$  fullrange drivers with phase plug
- Very linear frequency response
- 180 watts power capacity
- 8 ohms or 100 V versions
- Modular aluminium cabinet

### Fields of Application

- Churches
- Concert halls, theatres
- Exhibitions, trade fairs
- Large rooms, halls
- Mobile systems
- Museums

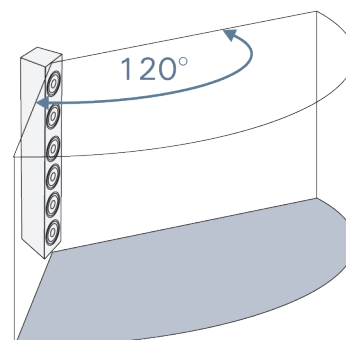

Directional characteristics

# ZL 50 Line Array Speaker

## Dimensions

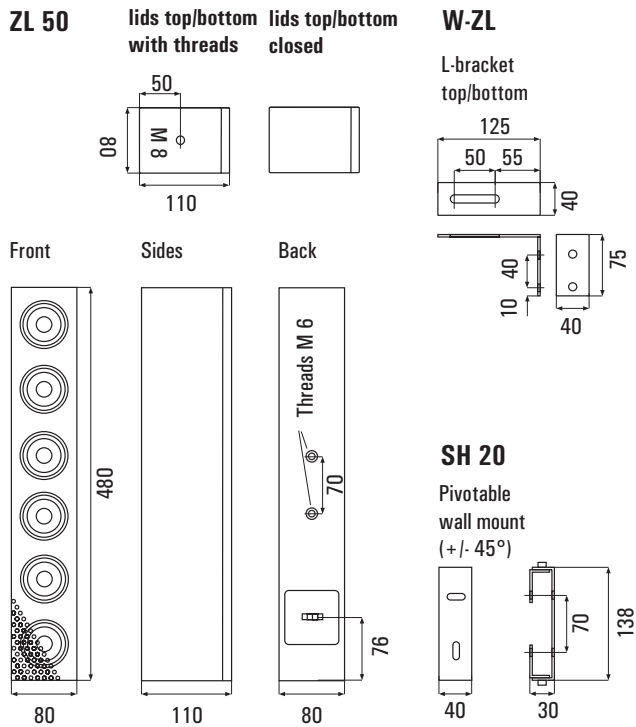

Front without grille



Connector



W-ZL L-bracket

## Technical Data

Principle	Line array with 6 full-range drivers
Components	6 × 2.5" long excursion full-range drivers with phase plug and neodymium magnet system
Frequency range	120 Hz – 20 kHz
Impedance	8 ohms
Power capacity	90 watts RMS, 180 watts program
Sensitivity	90 dB (1 W @ 1 m)
Maximum SPL	111 dB @ 1 m, 100 V version: 108 dB @ 1 m
Nominal dispersion (H × V)	120° × 20°
Dimensions (W × H × D)	80 × 480 × 110 mm
Weight	2.8 kg
Cabinet	Aluminium, front metal grille, lid closed or optionally threaded inserts M 8 at top/below, finish: powder coated (Please specify bracket type when placing your order)
Connectors	Screw-type terminals, pluggable
Warranty	5 years

Model	Order-No.	Version
ZL 50 White	1002-0001	RAL 9016
ZL 50 Black	1002-0002	RAL 9005
ZL 50 T White	1002-0003	100 V version
ZL 50 T Black	1002-0004	Power 7.5/15/30 watts

Other length and colours on request

Zubehör	Artikel-Nr.	Ausführung
W-ZL White	7110-0005	L-bracket (pair)
W-ZL Black	7110-0006	L-bracket (pair)
SH 20 White	7110-0001	Wall mount
SH 20 Black	7110-0002	(+/- 45°)

# ZL 50

## Line Array Speaker

### Measuring Diagramm

ZL 50 Sens. @ 2, 83V/1m, d=4m

